

水路用L型 (農政局型 L-2000)

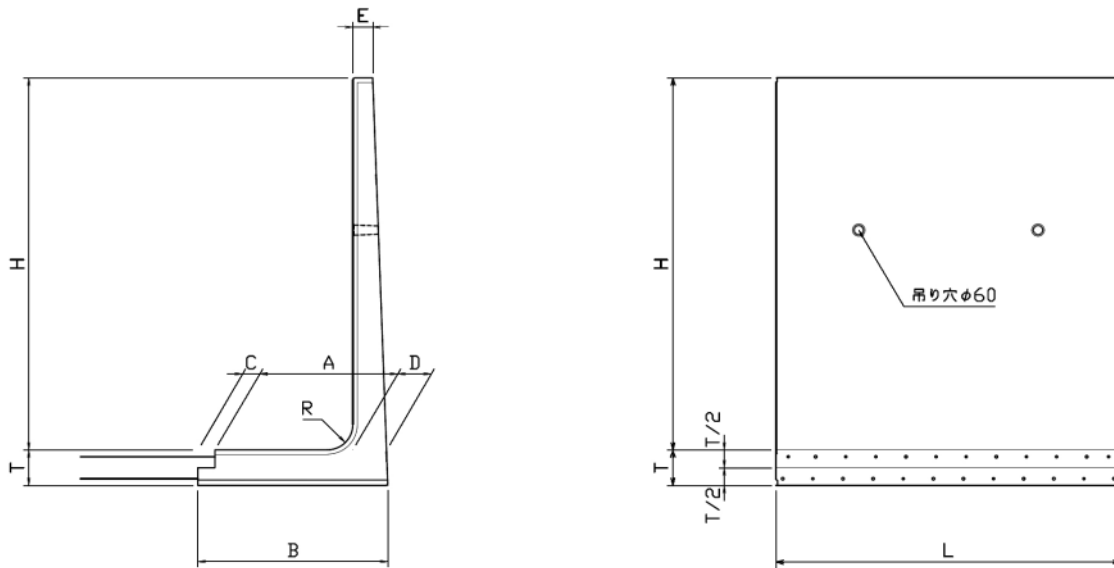

呼称 H	参考質量 (kg)	寸法(mm)						
		A	B	C	D	E	T	r
900	897	420	615	80	115	115	150	80
1000	951	420	615	80	115	115	150	80
1100	1005	420	615	80	115	115	150	80
1200	1059	420	615	80	115	115	150	80
1300	1200	500	721	100	120	115	150	100
1400	1254	500	721	100	120	115	150	100
1500	1424	500	736	100	135	121	155	150
1600	1480	500	736	100	135	120	155	150
1700	1748	600	852	100	150	126	165	150
1800	1807	600	852	100	150	125	165	150
1900	2136	700	981	100	175	118	185	150
2000	2192	700	981	100	175	115	185	150
2100	2606	800	1103	100	195	119	210	150
2200	2660	800	1103	100	195	115	210	150
2300	3151	900	1230	100	220	124	230	150
2400	3210	900	1230	100	220	120	230	150
2500	3722	900	1257	100	245	130	265	160
2600	3781	900	1257	100	245	125	265	160
2700	4439	1000	1385	100	270	135	295	170
2800	4500	1000	1385	100	270	130	295	170