

形状及び寸法表 (大型車両：横断走行)

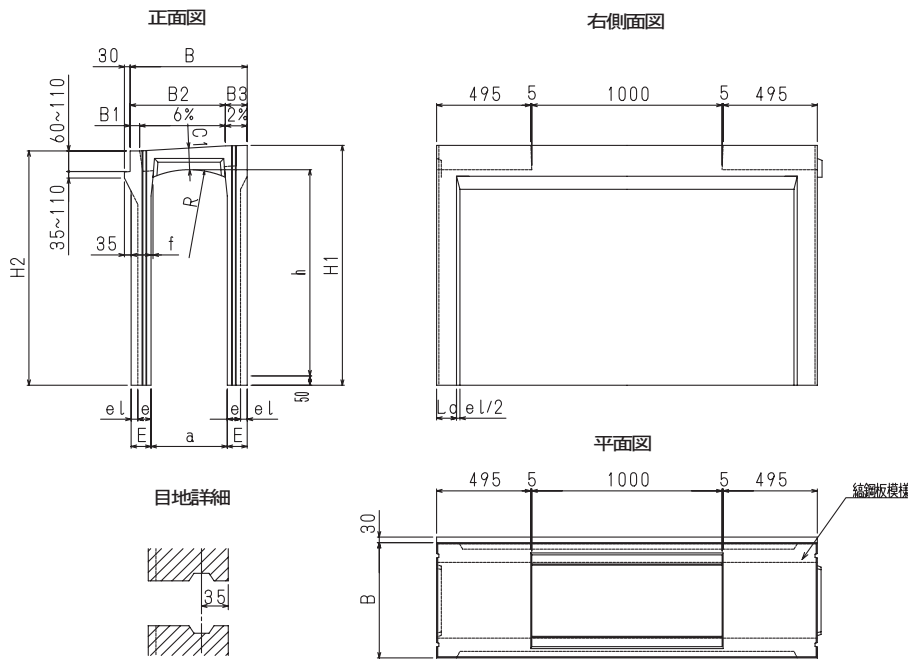

呼 称 a × h	参考質量 (Kg)	寸 法 (mm)														
		B	B1	B2	B3	H1	H2	C1	E	e	e1	R	Lo	f		
300 × 300	405	505	45	500	5	466	438	100	100	65	35	360	90	10		
300 × 400	461					566	538								55	45
300 × 500	517					666	638								80	20
300 × 600	615					766	738									
300 × 700	679					866	838									
300 × 800	744					966	938									
300 × 900	917					1066	1038			1166	1138					
300 × 1000	994					1166	1138									
300 × 1100	1071					1266	1238									

● 蓋版

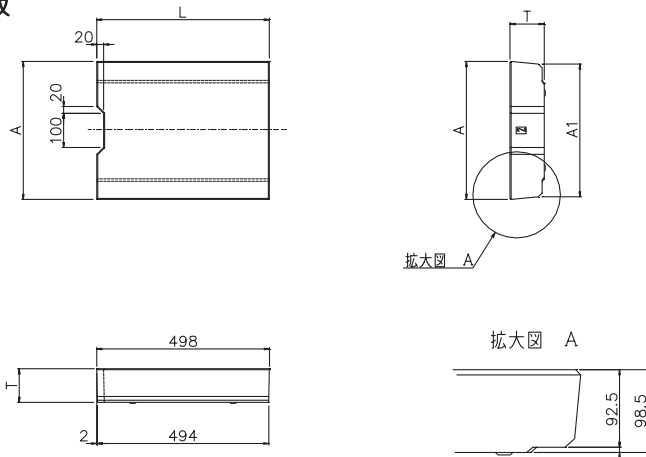

呼 称	参考質量 (Kg)	寸 法 (mm)		
		A	A1	T
300	44	405	387.5	98.5